

Mazak

VCN

SERIES

[Vertical Machining Center]



Advanced features of the MAZATROL SmoothG CNC

Touch screen operation – Operates similar to your smart phone / tablet

PC with Windows® 10 embedded OS

Fastest CNC in the world – Latest hardware and software for unprecedented speed and precision

Easy conversational programming of multiple surface machining

Smooth graphical user interface and support functions for unsurpassed ease of operation

Fine tuning functions – Easily configure machine parameters for different workpiece materials and application requirements

MTConnect® ready – Convenient networking



MAZATROL
SMOOTHG

Windows is a registered trademark of Microsoft Corporation in the United States and other countries.
MTConnect is a registered trademark of AMT in the United States and other countries.

VCN-500, VCN-600, VCN-700

Designed for performance, productivity and precision

Next generation vertical machining center – VCN series

Feedrate: 42m/min., Spindle speed 15,000 min⁻¹, Tool-to-tool 1.3 seconds

- ▶ Large working area and generous table sizes
- ▶ High-rigidity, high-accuracy machine construction
- ▶ Ideally suited to modern high-performance, dynamic milling techniques
- ▶ Designed with automation in mind



VCN-500

Table size : 1,050 mm x 500 mm
Axis Travel : X 800 mm
 Y 500 mm
 Z 550 mm



VCN-600

Table size : 1,300 mm x 600 mm
Axis Travel : X 1,050 mm
 Y 600 mm
 Z 600 mm



VCN-700

Table size : 1,500 mm x 700 mm
Axis Travel : X 1,300 mm
 Y 700 mm
 Z 650 mm

Machine design

High-rigidity, high-accuracy machine construction

Meehanite cast iron C Frame structure with wide base A-frame column. Designed using CAD FEMA to maximise machine rigidity and minimise distortion.

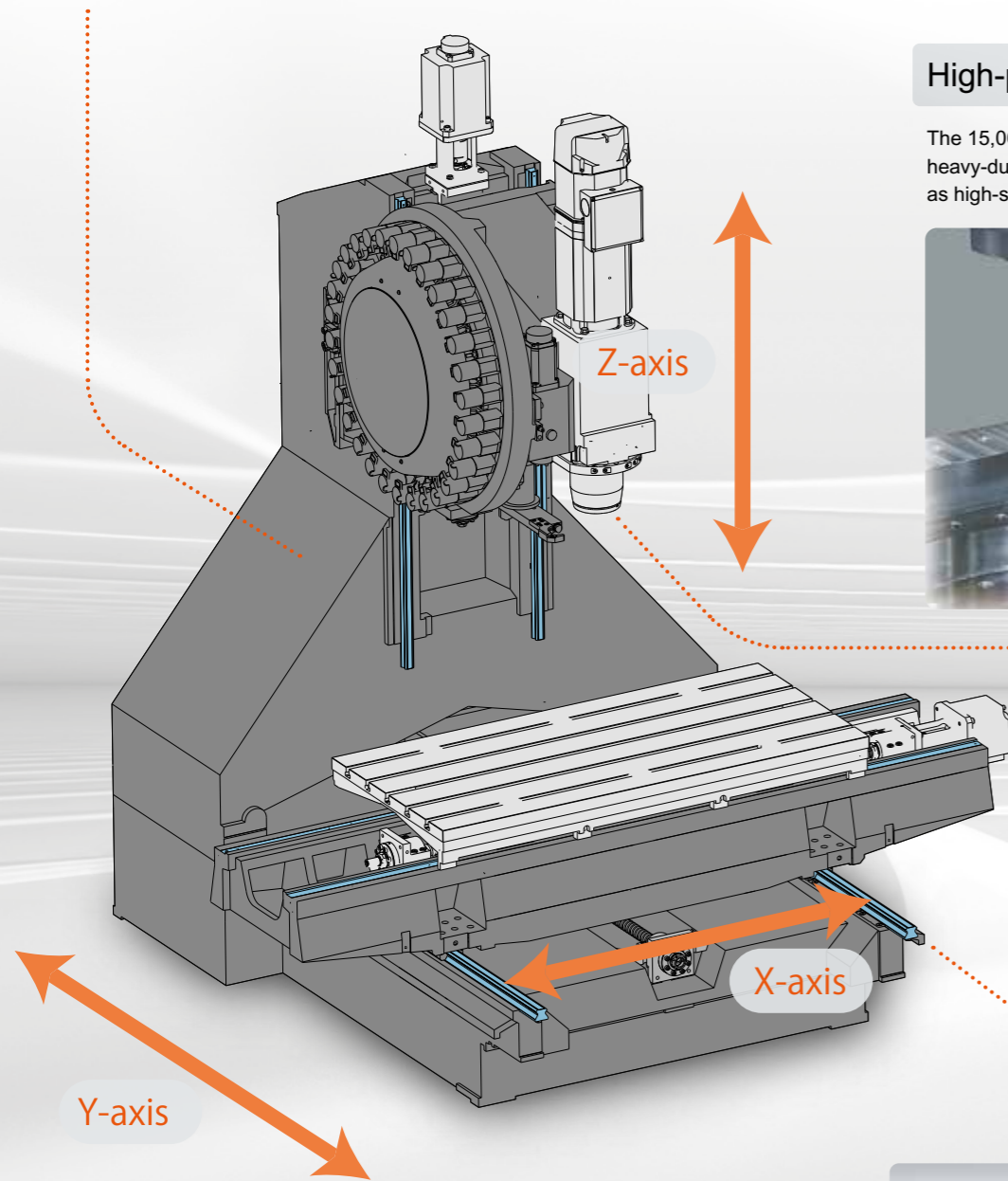

High-performance spindle

The 15,000 min⁻¹ spindle can perform heavy-duty machining of steel as well as high-speed and dynamic milling.



Linear roller guides on all axes

The rigid linear roller guides utilised on all linear axes provide improved positioning accuracy compared to slideways. Stable machining accuracy is ensured over an extended time period.



High-accuracy

Precision

Direct drive servo motors

Servo motors are directly mounted on the pretensioned X/ Y/ Z-axes ballscrews to eliminate backlash. High-resolution encoders with 4,000,000 pulses ensure high-accuracy positioning and contouring.



Machining accuracy

Ai Thermal Shield

Ai Thermal Shield ensures enhanced heat displacement compensation. New algorithms automatically determine the amount of compensation to be applied according to changes in the temperature to ensure even higher machining accuracy.

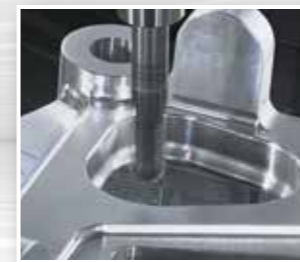

Machining



Workpiece inspection



Simulation

X-, Y- and Z-axes

Ball screw core cooling

Temperature controlled cooling through the ballscrews ensures stable machine accuracy over extended periods of operation.

- ▶ Optional with 15,000 min⁻¹.
- ▶ Included as standard with optional 18,000 min⁻¹ spindle.

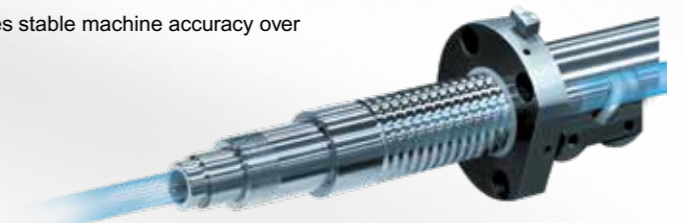

High-productivity

High-productivity machining is realised thanks to the new range of high-performance spindles designed to satisfy the demands of modern dynamic machining techniques.



High-performance spindle

Newly designed high-performance spindle ideally suited to heavy-duty machining as well as high-speed and dynamic machining of a wide range of materials.

Max. spindle speed	15,000 min ⁻¹
Spindle output	22 / 11 / 11 kW 10% ED / 40% ED / Continuous
Max. torque	119 / 70 / 57.3 Nm 10% ED / 40% ED / Continuous

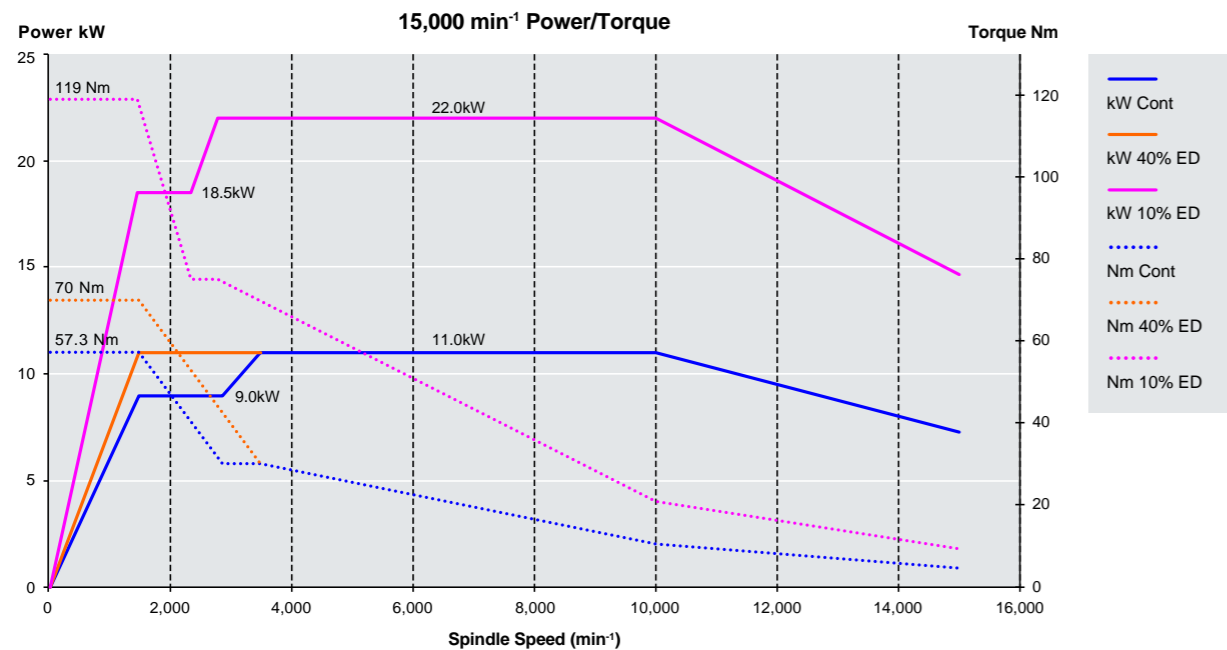

High-speed spindle

OPTION

Powerful high-speed 18,000 min⁻¹ / 30 kW / 120 Nm spindle with integral motor and circulated cooling for improved metal removal rates and high-speed, high-accuracy machining applications.

Max. spindle speed	18,000 min ⁻¹
Spindle output	30 / 30 / 22 kW 15/30% ED / 40% ED / Continuous
Max. torque	120 / 84 / 57.3 Nm 15/30% ED / 40% ED / Continuous

 Ballscrew core cooling is included as standard with the optional 18,000 min⁻¹ spindle.

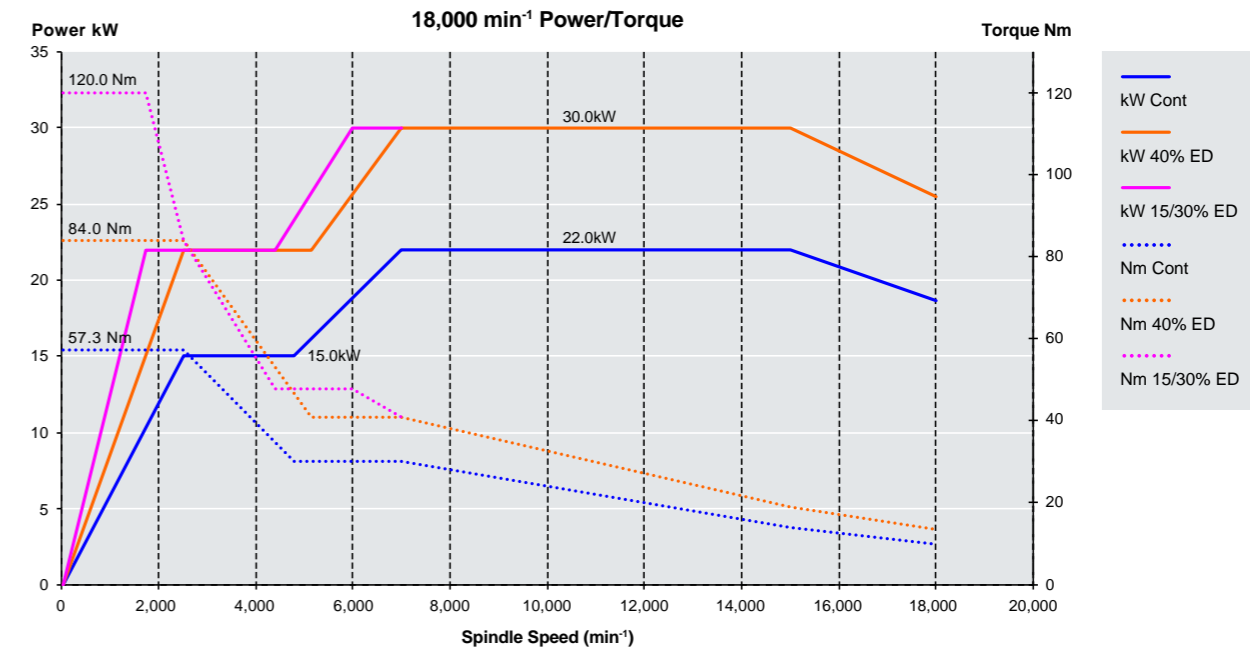

Extensive machining applications



Material : Aluminum
Workpiece : Medical component



Material : Prehardened steel
Workpiece : Automotive component die



Material : Aluminum
Workpiece : Automotive component motor case



Material : Carbon steel
Workpiece : General industry machinery component



Material : Carbon steel
Workpiece : General industry machinery component



Material : Prehardened steel
Workpiece : Die and mold press tool component

Automatic tool changer and magazine

High-speed automatic tool changer

The cam-driven double arm tool change system is designed for reliability and high-speed, reducing non-cutting time to a minimum.

Tool change time
(tool-to-tool)
1.3 sec.

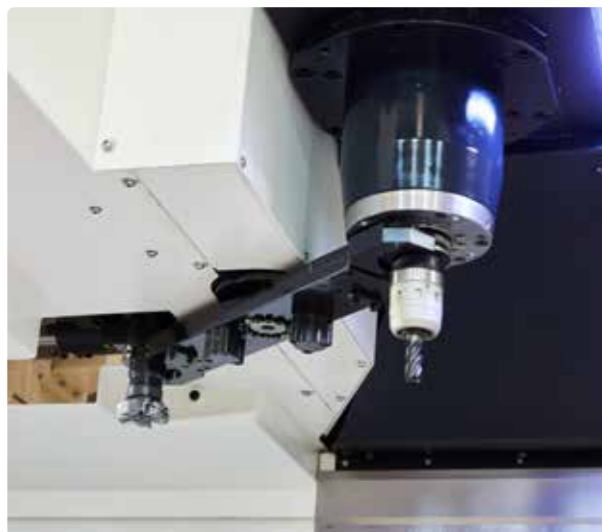

High-speed magazine

The servo-driven drum type tool magazine has a capacity for 30 tools as standard. High-speed rotation and random tool pocket configuration increase efficiency and reduce non-cutting time.



48 or 60 tool magazine

OPTION

48 or 60 tool chain type magazines are available for increased flexibility and productivity. The generous magazine capacity provides ample tool storage for complex workpieces and high-mix production as well as spare tools for prolonged continuous operations.



Tool magazine loading door

Tools can be easily loaded / unloaded whilst the machine is in automatic operation through the standard tool magazine loading door.



Set-up

Tool identification

OPTION

Tool ID allows automatic input and update of tool data into the CNC (or machines in a network). This eliminates data-input errors and reduces set-up time when loading tools into the magazine. (Available for Mazak Euchner Tool ID or Balluff RFID systems).



Smooth Ai spindle

OPTION

Using AI, the milling spindle vibration is detected and machining conditions are automatically changed to produce unsurpassed surface finishes and high productivity. Thanks to AI, adjustments can be easily made in a short time without a skilled operator.

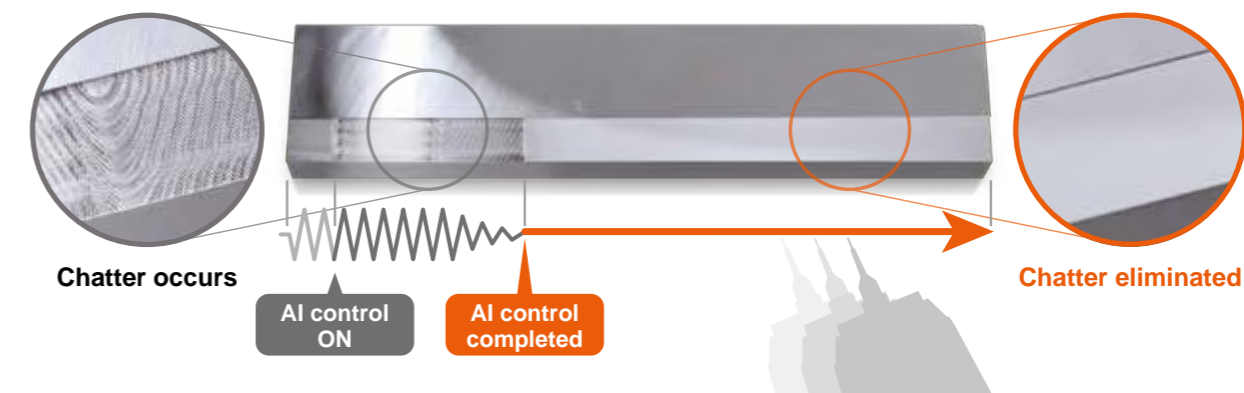

Remote manual pulse generator

OPTION

The remote manual pulse generator provides convenient operation when the operator cannot reach the handwheel on the CNC operation panel.

The handheld unit displays the machine coordinate value and the tool position relative to the workpiece offset. Up to four different coordinate points can be registered in memory.



Ergonomics

Maintenance area

All the items that require frequent access, such as valves and lubrication inlets, are at the same location to make daily maintenance more convenient.



Convenient tool camp / unclamp

The tool camp / unclamp switches mounted next to the spindle allow the tool to be easily removed directly from the spindle.



Single-sided door with large window

A wide opening single-sided door with a fully enclosed cover provides convenient single-handed operation and easy component loading. The large window offers excellent visibility of the machining area.



Adjustable touch panel

The tilting operation panel allows optimum positioning of the touch panel and ensures comfortable operation for operators of any height.

Tilt 45°
Rotate 90°

Accessibility to table and spindle

A convenient recess at the base of the machine for the operator's feet provides increased ease of access to the machine table.



Removable coolant tank

The wheeled coolant tank can be removed from the front of the machine. This minimises the maintenance area required for cleaning.



Coolant and chip disposal

Flood coolant

Coolant is discharged from nozzles surrounding the spindle housing to provide cooling for the cutting tool and to remove chips from the workpiece.



Coolant through spindle

Coolant is fed directly to the tool tip through the tool holder and is particularly effective for drilling and removing chips from internal features such as pockets.



High-pressure coolant through spindle

OPTION

High-pressure coolant through the spindle, up to 7.0 MPa, provides ultimate chip control and lubrication during high-performance machining operations. Using M-codes, the pressure is varied at three programmable stages for 2.0, 5.0 and 7.0 MPa. Coolant is filtered to 20µm by an integrated turbulence filter to minimise maintenance and reduce running costs.



Spindle air package

OPTION

The spindle air package combines 'workpiece air blast' and 'through spindle air with rotation' to remove chips from the workpiece and tool for machining operations where coolant is not required.

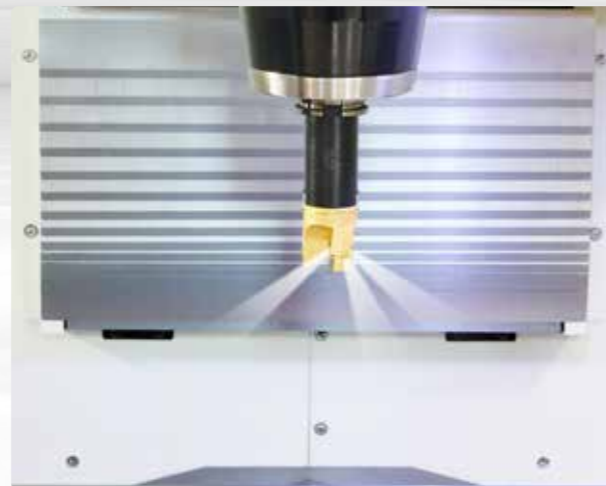

Coolant packages

OPTION

A comprehensive selection of coolant and chip management systems are available to suit various chip types and preferred maintenance intervals.

Package	Contents	Conveyor	Chip Type	Maintenance level
1	<ul style="list-style-type: none"> ▶ 0.5MPa through & flood coolant ▶ Chip tank (lift out baskets) 	None	<ul style="list-style-type: none"> ▶ Mixed steels material handling ▶ Chip length ≥5mm ▶ Low volume applications 	
2	<ul style="list-style-type: none"> ▶ 2.0 MPa through & flood coolant ▶ Spiral conveyors ▶ Cover coolant ▶ Hinge type chip conveyor 	<ul style="list-style-type: none"> ▶ LNS ▶ Cromar ▶ Mayfran 	<ul style="list-style-type: none"> ▶ Mixed steels material handling ▶ Chip length ≥5mm ▶ Medium volume applications 	
3	<ul style="list-style-type: none"> ▶ 2.0 MPa through & flood coolant ▶ Spiral conveyors ▶ Cover coolant ▶ Entry level chip management system 	<ul style="list-style-type: none"> ▶ LNS Turbo MH500 ▶ Cromar Combi 500 ▶ Mayfran CleanSweep 	<ul style="list-style-type: none"> ▶ Mixed material handling ▶ Chip length ≥0.25mm ▶ 250/500µ filtration ▶ Medium / high volume production 	
4	<ul style="list-style-type: none"> ▶ 2.0 MPa through & flood coolant ▶ Spiral conveyors ▶ Cover coolant ▶ Performance chip management system 	<ul style="list-style-type: none"> ▶ LNS Turbo SF Compact ▶ Cromar Series IV ▶ Mayfran Consep 	<ul style="list-style-type: none"> ▶ All material types ▶ Chip length ≥0.25mm ▶ 50/25µ filtration ▶ Continuous high volume production 	
5	<ul style="list-style-type: none"> ▶ 7.0MPa through coolant (3-Stage) ▶ 0.5MPa flood coolant ▶ Spiral conveyors ▶ Cover coolant ▶ Entry level chip management system 	<ul style="list-style-type: none"> ▶ LNS Turbo MH500 ▶ Cromar Combi 500 ▶ Mayfran CleanSweep 	<ul style="list-style-type: none"> ▶ Mixed material handling ▶ Chip length ≥0.25mm ▶ 250/500µ filtration ▶ Medium / high volume production 	
6	<ul style="list-style-type: none"> ▶ 7.0MPa through coolant (3-Stage) ▶ 0.5MPa flood coolant ▶ Spiral conveyors ▶ Cover coolant ▶ Performance chip management system 	<ul style="list-style-type: none"> ▶ LNS Turbo SF Compact ▶ Cromar Series IV ▶ Mayfran Consep 	<ul style="list-style-type: none"> ▶ All material types ▶ Chip length ≥0.25mm ▶ 50/25µ filtration ▶ Continuous high volume production 	

Package	Stringy swarf	Mixed swarf	Small chipped swarf	Fine swarf
1	○	×	×	×
2	○	○	×	×
3	○	○	○	×
4	○	○	○	○
5	○	○	○	×
6	○	○	○	○

○: Suitable X: Unsuitable

Measurement packages

OPTION

For ease of set-up and repeated workpiece accuracy, a comprehensive range of measurement packages combine Renishaw's cable-free radio transmission technology to offer the following advantages.

- ▶ Automatic tool length and diameter measurement
- ▶ Tool breakage detection
- ▶ Automatic datum setting
- ▶ Automatic workpiece measurement



Automatic tool measurement

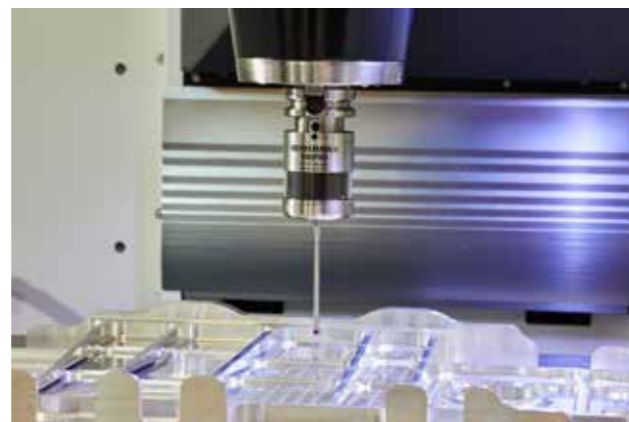

Workpiece datuming and measurement

Measurement package 1

- ▶ Renishaw RMI-Q multiple probe radio interface
- ▶ Renishaw RTS radio tool setter

(Measurement package 1 includes preparation for the touch probe)



RMI-Q



RTS

Measurement package 1

Measurement package 2

- ▶ Renishaw RMI-Q multiple probe radio interface
- ▶ Renishaw RTS radio tool setter
- ▶ Renishaw RMP-60 radio transmission touch probe
- ▶ Renishaw Set & Inspect
- ▶ Mazak API



RMP-60



Renishaw Set and Inspect
Includes Mazak API

Measurement package 2

Automation

Designed with automation in mind

The VCN series can be easily integrated with various automation solutions thanks to the optional automation packages that include a side or front loading door, robot interface and hydraulic or pneumatic fixture preparation.



MA - Mill Assist

OPTION

The MA-25 or 35/400 is a user-friendly automated robotic loading system realising enhanced productivity, machine utilisation and the ability to increase unmanned running. The GUI is integrated into SmoothG controller for a seamless interface between machine and robot operation. Parametric style data entry makes it extremely fast to program and set-up.

NC rotary tables

OPTION

Optional factory fitted Kitagawa GT series high precision rotary 4th axis. Offering superior speed and clamping torque for high-rigidity rotary axis positioning and machining.

	VCN-500	VCN-600	VCN-700
Kitagawa Model No:	GT200	GT250	GT320
Face Plate Diameter	200 mm	250 mm	320 mm
Max Rotation Speed	41.6 min ⁻¹	33.3 min ⁻¹	25 min ⁻¹
Clamping Torque	820 Nm	1,600 Nm	2,800 Nm

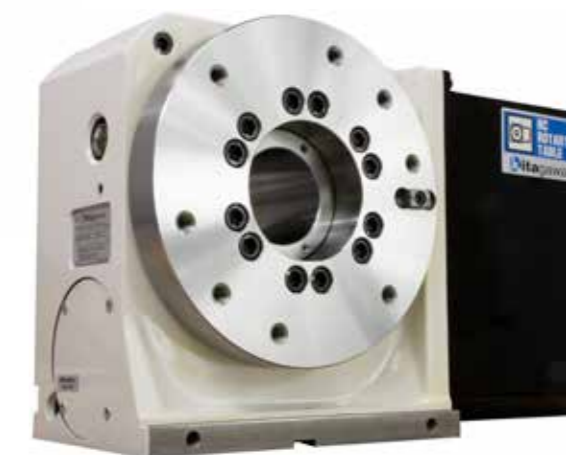

MAZATROL CNC System

MAZATROL SMOOTHG 4-axes simultaneous CNC



Shown with optional dual monitor

Advanced CNC control

– Latest hardware and software for unprecedented speed and precision

Smooth graphical user interface

MAZATROL Smooth graphical user interface for unsurpassed ease of operation
Touch screen operation – operates similar to your smartphone / tablet

Ease of operation

Designed for unsurpassed ease of operation with advanced functions

Windows is a registered trademark of Microsoft Corporation in the United States and other countries.

Process home screens

Five different home process screens – each home screen displays the appropriate data in an easy-to-understand manner. Icons can be touched in each process display for additional screen displays.



Programming



Tool data



Set up



Machining



Maintenance

Programming screen links tool path, workpiece shape and programming to reduce programming time

QUICK MAZATROL

MAZATROL program, unit list and 3D workpiece shape are linked to each other. After defining a machining unit in a MAZATROL program, the 3D shape is immediately displayed to easily and quickly check for any programming error.

Quickly move to the corresponding section in the MAZATROL program by touching a feature in the 3D model.

3D model in the process list is displayed with updated programming in real time.

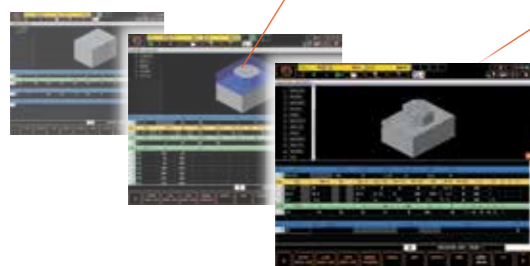

3D ASSIST

Workpiece and coordinates data can be imported from 3D CAD data to a MAZATROL program. No coordinate value inputs are required. Can reduce input errors and time for program checking.

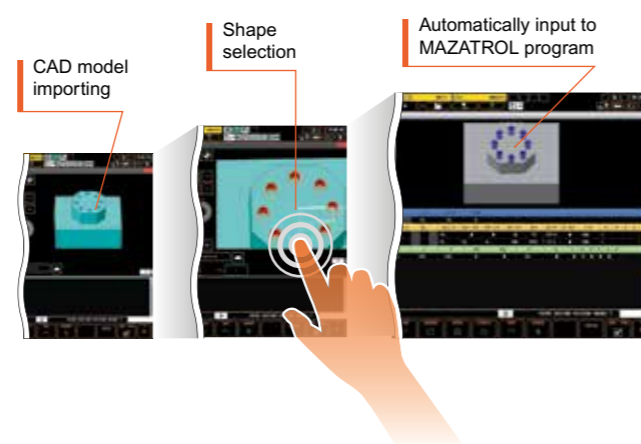

QUICK EIA

Program, process list and 3D tool path display are linked to each other. Visible search on touch screen can reduce the time for program checking.

Selecting tool path by touching the screen.

Moving to the corresponding EIA program line.



VIEW SURF

By analysing the tool path, any predictable failure on the finished surface can be visualised. Program modification can be done before machining to minimise the time for test cutting.

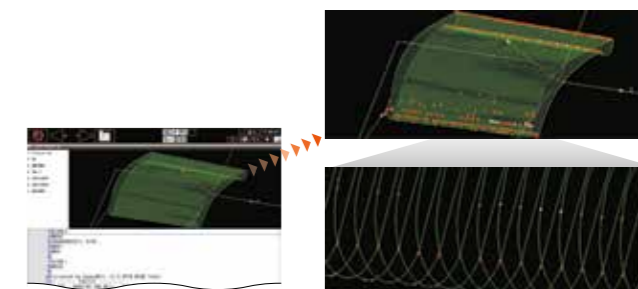

Smooth machining configuration

Optimise programs just by using a touchscreen slider

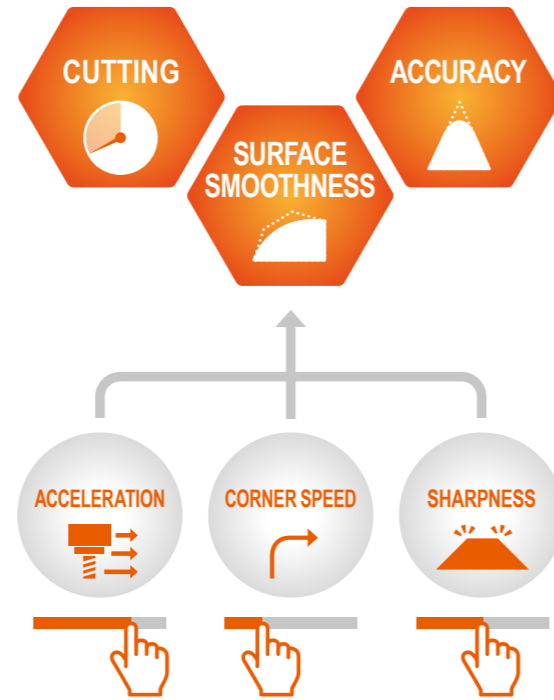

Previously complicated procedures to adjust machine CNC parameters are eliminated by the MAZATROL Smooth Machining Configuration (SMC).

Simple-to-use touch screen sliders easily adjust machine parameters governing feedrate velocity, surface smoothness and contouring accuracy according to the desired machining process, i.e., roughing, semi-finishing and fine finishing. SMC is especially effective for complex workpiece contours defined in small program increments.

Finishing time comparison

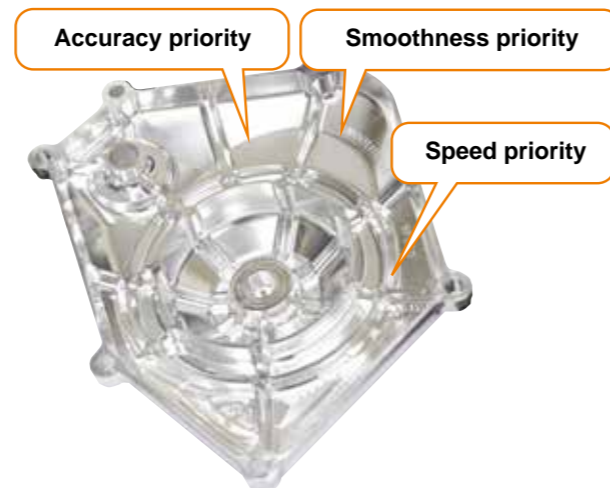
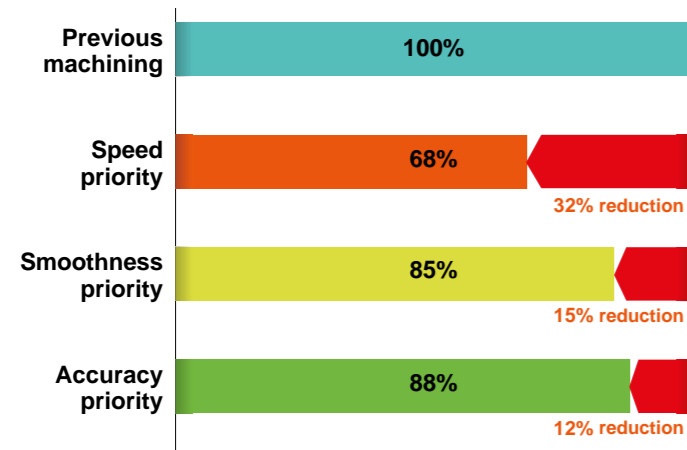

Ultraspindle

OPTION

With spindle speeds of 60,000 or 80,000 min⁻¹ the Ultraspindle provides an economical way of achieving superfinishing operations for die and mold work. It is also suitable for small diameter drilling, grinding, engraving and deburring operations.

Ultra high-speed

- ▶ High-precision and accuracy
- ▶ Run-out < 1 micron
- ▶ Reduced finishing operation cycle times
- ▶ Improved surface finish quality
- ▶ Reduced hand finishing and polishing

Spindle features

- ▶ Brushless electric driven motor
- ▶ Fully CNC controlled - M-codes and S-codes to command spindle
- ▶ Max. axial thermal displacement 2 Microns
- ▶ Cost effective solution in comparison to conventional high-speed spindle machines
- ▶ The machine stopper block incorporates an automatic shutter to prevent the ingress of chips and coolant

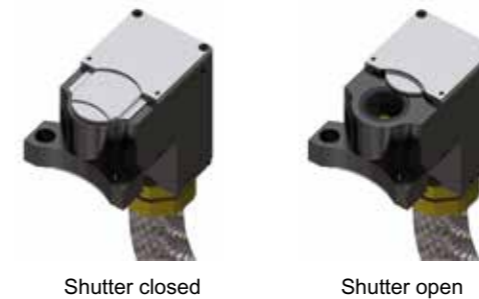

60,000 min⁻¹ Ultraspindle

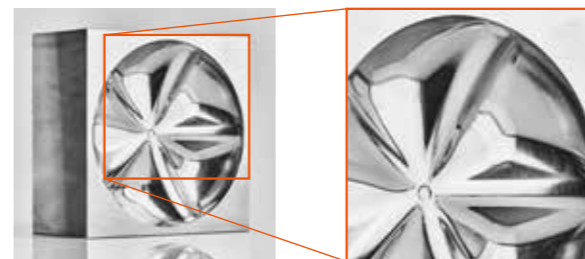

12,000 min⁻¹ Spindle

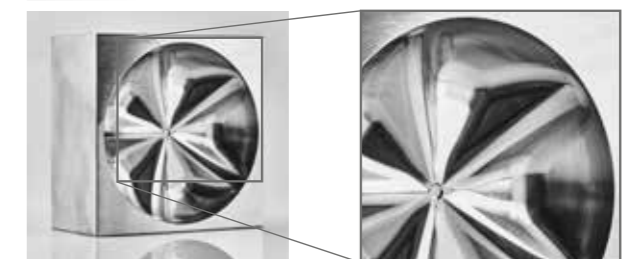

The Ultraspindle can reduce processing time by 68%*



60,000 min⁻¹ Ultraspindle total machining time:

2.5 hours

12,000 min⁻¹ Spindle total machining time:

8 hours

Material: **NAK80**
(pre-hardened steel 37-43 HRC)

Material size:
W100 mm x D100 mm x H50 mm

Support

Connect machines, connects future

Mazak iCONNECT™

Mazak iCONNECT is a service that supports productivity improvement by connecting the customers' Mazak machines to Mazak. Through iCONNECT, Mazak provides various services, such as processing support, operation monitoring and maintenance support.

Mazak free web portal

The Mazak iCONNECT service is available to all Mazak machine owners. You just need to register and you will get access to the following functions:

- List of installed machines
- Download Manuals
- Spare parts order records
- Mazak e-learning
- Software Download
- Machine FAQ
- Maintenance video

Machine FAQ

You can check the history of services visitors provided by service engineer.

Check whenever date and details of your service visits.

Maintenance video

Check maintenance videos to reduce maintenance requested time.

For maintenance reference

M2M - Connected machine

With M2M service your machine will be connected securely to cloud, providing monitoring of machine operations and remote diagnosis.

- Dashboard (check your machine through an easy to use interface)
- Machine operations report
- Security
- Maintenance manager
- Machine list

- CNC backup to cloud
- Machine remote diagnosis
- Service call
- Set up manager
- Contact us

Environment commitment

Designed with environmental considerations

Yamazaki Mazak has positioned environmental initiatives as one of its essential management issues. We are promoting activity to reduce CO₂ emissions throughout the product life cycle. This is shown by the fact that all factories where Mazak machine tools are produced are ISO 14001 certified, an international standard confirming that the operation of our production facilities does not adversely affect air, water or land.

The VCN series is designed with a transformerless electrical power connection that reduces energy consumption by up to 6%.

Mazak Go GREEN

Extended coolant service life

Reduction of lubrication consumption

Reduction of electrical power consumption

Energy Dashboard for saving energy MAZATROL SMOOTHG OPTION

The Energy Dashboard provides convenient visual monitoring of energy consumption and analysis. Energy consumption, electrical power cost, and CO₂ emission are displayed.

Energy consumption displayed on graph

Energy consumption by workpieces

Display approximate CO₂ emission and electrical power cost

Energy consumption on process screen display

- Total energy consumption (of workpiece in operation)
- Current energy consumption

Machine specifications

Standard Machine Specifications

		VCN-500	VCN-600	VCN-700
Stroke	X axis travel (table left/right)	800 mm	1,050 mm	1,300 mm
	Y axis travel (Saddle back/forth)	500 mm	600 mm	700 mm
	Z axis travel (Spindle up/down)	550 mm	600 mm	650 mm
	Distance from table top to spindle nose	150 - 700 mm	150 - 750 mm	150 - 800 mm
Table	Table size	1,050 mm x 500 mm	1,300 mm x 600 mm	1,500 mm x 700 mm
	Load capacity	750 kg	1,200 kg	1,800 kg
	Table surface configuration	18 mm T-Slot x 5		
	T-Slot pitch	100mm	125mm	
Standard Spindle	Max. spindle speed	15,000 min ⁻¹		
	Spindle speed range	35 - 15,000 min ⁻¹ (2-Step Electric)		
	Spindle taper	7/24 taper No. 40 (*1/10 taper HSK A63)		
	Spindle bearing OD	Ø110 mm		
	Spindle power (10% ED / 40% ED / Cont.)	22 / 11.0 / 11.0 kW		
	Spindle torque (10% ED / 40% ED / Cont.)	119 / 70.0 / 57.3 Nm		
Optional Spindle	Max. spindle speed	18,000 min ⁻¹		
	Spindle speed range	35 - 18,000 min ⁻¹ (2-Step Electric)		
	Spindle taper	7/24 taper No. 40 (*1/10 taper HSK A63)		
	Spindle bearing OD	Ø100 mm		
	Spindle power (10% ED / 40% ED / Cont.)	30.0 / 30.0 / 22.0 kW		
	Spindle torque (10% ED / 40% ED / Cont.)	120.0 / 84.0 / 57.3 Nm		
Feedrate	Rapid traverse rate (X, Y, Z axis)	42 m/min		
	Cutting Feedrate rate (X, Y, Z axis)	1 ~ 42,000 mm/min		
Automatic tool changer	Tool Shank	CAT No.40 (*BT40, *BBT40, *HSK A63)		
	Tool storage capacity	30 (48* / 60*)		
	Max. tool diameter	Ø80 mm		
	Max. tool diameter (adj pockets empty)	Ø125 mm		
	Max. Tool length (from gauge line)	350 mm		
	Max. Tool weight	8 kg		
	Tool selection method	MAZATROL random memory / shortest path		
	Tool change time (tool-to-tool)	1.3 secs		
Power Services	Electrical power supply (Cont.)	> 50kVA		
	Air supply	0.5 - 0.9 Mpa		
Machine size	Height	2,863 mm	2,938 mm	3,013 mm
	Width (including hinge type conveyor*)	3,500 mm	3,935 mm	4,505 mm
	Depth (including CNC pendant)	2,989 mm	3,279 mm	3,571 mm
	Weight	>6,000 kg	>7,000 kg	>9,000 kg
CNC	MAZATROL Smooth G			

* = Option

MAZATROL SmoothG specifications

	MAZATROL	EIA
Number of controlled axes	Simultaneous 2 ~ 4 axes	
Least input increment	0.0001 mm, 0.00001 inch, 0.0001 deg	
High-speed, high precision control	Shape compensation, Smooth corner control, Rapid traverse overlap, Rotary axis shape compensation	Shape compensation, Smooth corner control, Rapid traverse overlap, Rotary axis shape compensation, High-speed machining mode, High-speed smoothing control
Interpolation	Positioning (interpolation), Positioning (non-interpolation), Linear interpolation, Circular interpolation, Synchronous tapping*	Positioning (interpolation), Positioning (non-interpolation), Linear interpolation, Circular interpolation, Spiral interpolation, Helical interpolation, Cylindrical interpolation*, Fine spline interpolation*, NURBS interpolation*, Polar coordinate interpolation*, Synchronous tapping*
Feedrate	Rapid traverse, Cutting feed, Cutting feed (per minute), Cutting feed (per revolution), Dwell (time / rotation), Rapid traverse override, Cutting feed override, G0 speed variable control, Feedrate limitation, Variable acceleration control, G0 slope constant*	Rapid traverse, Cutting feed, Cutting feed (per minute), Cutting feed (per revolution), Inverse time feed, Dwell (time / rotation), Rapid traverse override, Cutting feed override, G0 speed variable control, Feedrate limitation, Time constant changing for G1, Variable acceleration control, G0 slope constant*
Program registration	Number of programs : 256 (Standard) / 960 (Max.), Program memory : 2 MB, Program memory expansion : 8 MB*, Program memory expansion : 32 MB*	
Control display	Display : 19" touch panel, Resolution : SXGA	
Spindle functions	S code output, Spindle speed limitation, Spindle speed override, Spindle speed reaching detection, Multiple position orient*, Constant surface speed, Spindle speed command with decimal digits, Synchronized spindle control, Spindle speed range setting	
Tool functions	Number of tool offset : 4,000, T code output for tool number, Tool life monitoring (time), Tool life monitoring (number of machined workpieces)	Number of tool offset : 4,000, T code output for tool number, T code output for group number, Tool life monitoring (time), Tool life monitoring (number of machined workpieces)
Miscellaneous functions	M code output, Simultaneous output of multiple M codes	
Tool offset functions	Tool position offset, Tool length offset, Tool diameter / tool nose R offset, Tool wear offset	
Coordinate system	Machine coordinate system, Work coordinate system, Local coordinate system, Additional work coordinates (300 set)	
Machine functions	-	
Machine compensation	Backlash compensation, Pitch error compensation, Ai Thermal shield, Volumetric compensation*	
Protection functions	Emergency stop, Interlock, Pre-move stroke check, SAFETY SHIELD (manual mode), SAFETY SHIELD (automatic mode)*, VOICE ADVISER	
Automatic operation mode	Memory operation	Memory operation, Tape operation, MDI operation, EtherNet operation*
Automatic operation control	Optional stop, Dry run, Manual handle interruption, MDI interruption, TPS, Restart, Machine lock	Optional block skip, Optional stop, Dry run, Manual handle interruption, MDI interruption, TPS, Restart, Restart 2, Collation stop, Machine lock
Manual measuring functions	Tool length teach, Touch sensor coordinates measurement, Workpiece offset measurement, WPC coordinate measurement, Measurement on machine	Tool length teach, Tool offset teach, Touch sensor coordinates measurement, Workpiece offset measurement, Measurement on machine
Automatic measuring functions	WPC coordinate measurement, Automatic tool length measurement, Sensor calibration, Tool breakage detection, External tool breakage detection*	Automatic tool length measurement, Sensor calibration, Tool breakage detection, External tool breakage detection*
MDI measurement	Semi automatic tool length measurement, Full automatic tool length measurement, Coordinate measurement	
Peripheral network	PROFIBUS-DP*, EtherNet/IP*, CC-Link*, CC-Link IE Field Basic*	
Interface	SD card interface, USB	
EtherNet	10 M / 100 M / 1 Gbps	

* Option

** Simultaneous 4-axis control

Machine

VCN Series Standard and Optional Equipment

ATC	ATC 30 tool magazine	●
	ATC 48 tool magazine	○
	ATC 60 tool magazine	○
Spindle	7/24 taper No.40 spindle - 15,000 min ⁻¹	●
	7/24 taper No.40 spindle - 18,000 min ⁻¹	○
	7/24 taper No.40 Big-Plus spindle connection	○
	1/10 taper HSK-A63 spindle connection	○
High-accuracy	Ballscrew core cooling (X, Y, Z-axis) (Included with 18,000 min ⁻¹)	○
	Scale feedback system (X, Y, Z-axis)	○
Factory automation	Absolute position detection	●
	Automatic power on / off and warm-up operation	●
	Magazine / Automatic tool changer door	●
	Signal tower (3 colour light)	○
	Manual pulse generator (detachable)	○
	Automatic front door auto open / close	○
	Tool ID system (Euchner or Balluff)	○
	Mazak Ultraspindle (60,000 or 80,000 min ⁻¹)	○
	Additional 6 M-codes	○
	Coolant and chip disposal	Spiral conveyors (Coolant package 1 only)
Cover coolant (Coolant package 1 only)		○
Hand held coolant nozzle		○
Oil skimmer		○
Coolant saver		○
Chip bucket (fixed or swing type)		○
Working environment	Enclosed roof cover	●
	Work light	●
	Additional work light	○
	Mist collector (preparation only)	○
	Mist collector	○
	Smooth Energy Dashboard	○
	Operation Mode 3	○
NCRT Options	4th Axis (preparation only)	○
	Kitagawa GT series 4th axis	○
	Manual scroll chuck / manual tailstock for GT series	○
Productivity package	- Memory expansion 8MB	○
	- Synronised tapping	
	- G00 Slope constant	
	- Signal tower (3 colour light)	
	- Manual pulse generator (detachable)	
	- Work air blast	
- Air through spindle with rotation		

● : Standard ○ : Option

Coolant & chip disposal packages

Coolant package 1	- Flood coolant 0.5MPa - Coolant through spindle 0.5MPa - Cover coolant - Spiral conveyors - Chip tank (Lift out baskets)	●
Coolant package 2	- Flood coolant 2.0MPa - Coolant through spindle 2.0MPa - Cover coolant - Spiral conveyors - Chip conveyor hinge type (left or right side)	○
Coolant package 3	- Flood coolant 2.0MPa - Coolant through spindle 2.0MPa - Cover coolant - Spiral conveyors - Entry level swarf management system (left or right side)	○
Coolant package 4	- Flood coolant 2.0MPa - Coolant through spindle 2.0MPa - Cover coolant - Spiral conveyors - Performance swarf management system (left or right side)	○
Coolant package 5	- Coolant through spindle 7.0MPa (3 stage by M-code) - Flood coolant 0.5MPa - Cover coolant - Spiral conveyors - Entry level swarf management system (left or right side)	○
Coolant package 6	- Coolant through spindle 7.0MPa (3 stage by M-code) - Flood coolant 0.5MPa - Cover coolant - Spiral conveyors - Performance swarf management system (left or right side)	○
Spindle air package	- Work air blast - Air through spindle with rotation	○

Measurement packages

Measurement package 1	- RMI-Q multiple probe radio interface - Renishaw RTS tool setting (Tool length measure & breakage detect)	○
Measurement package 2	- Renishaw RMI-Q multiple probe radio interface - Renishaw RMP60 touch sensor - Renishaw RTS tool setting (Tool length measure & breakage detect) - Mazak API - Renishaw Set & Inspect software	○

Factory automation packages

Side Loading Automation Package	- Automatic side loading door for robot (Right side) - Robot interface (Advanced Ethernet IP, Profibus or CC-link) - Preparation for hydraulic and pneumatic fixture clamping (4 x ports)	○
Front Loading Automation Package	- Automatic loading door for robot (Front) - Robot interface (Advanced Ethernet IP, Profibus or CC-link) - Preparation for hydraulic and pneumatic fixture clamping (4 x ports)	○
MA Automation Package (front or side loading)	- Automatic right side or front loading door for robot - Preparation for hydraulic and pneumatic fixture clamping (4 x ports) - Robot interface - Fixture interface - CE Conformity - Preparation for MA OEM Robot Cell	○

● : Standard ○ : Option

Machine dimensions

Reference slot

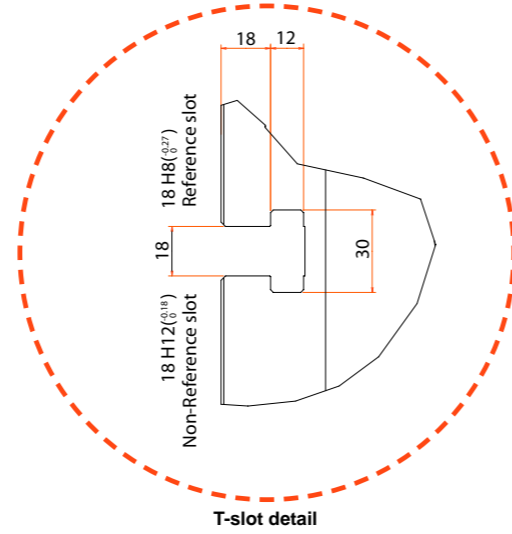
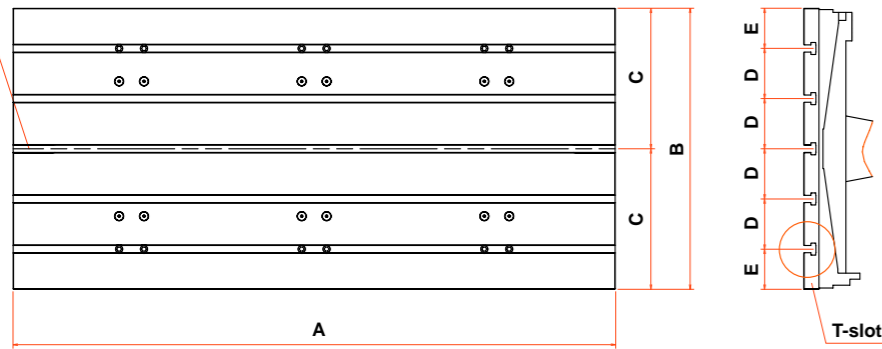

Specification	VCN-500	VCN-600	VCN-700
Dimension A (mm)	1,050	1,300	1,500
Dimension B (mm)	500	600	700
Dimension C (mm)	250	300	350
Dimension D (mm)	100	125	125
Dimension E (mm)	50	50	100

Interference of tools with workpiece when tools are changed

VCN-500

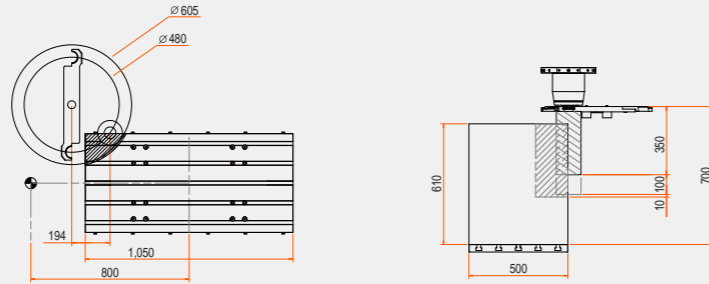

VCN-600

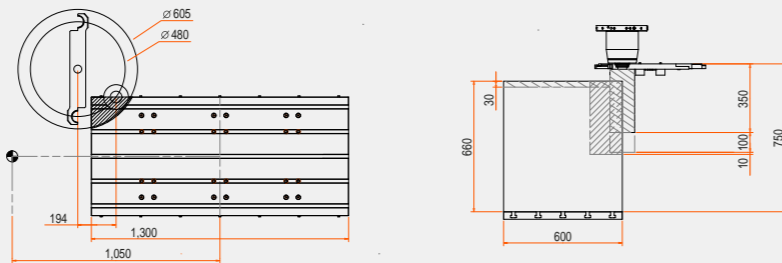

VCN-700

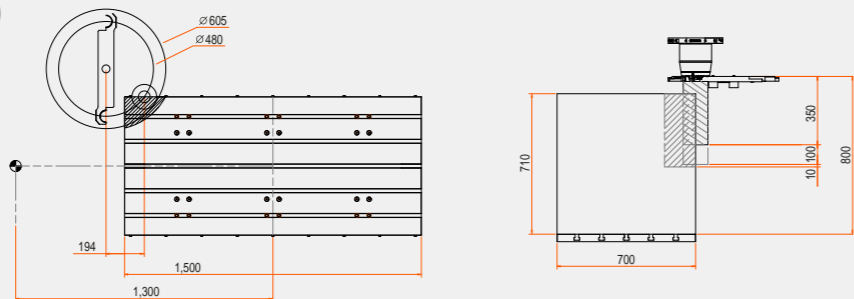

VCN-500

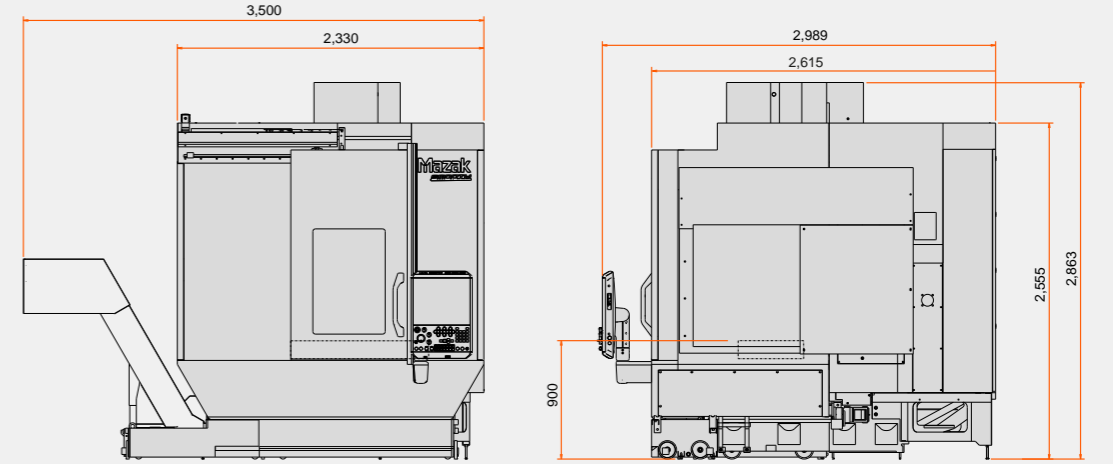

VCN-600

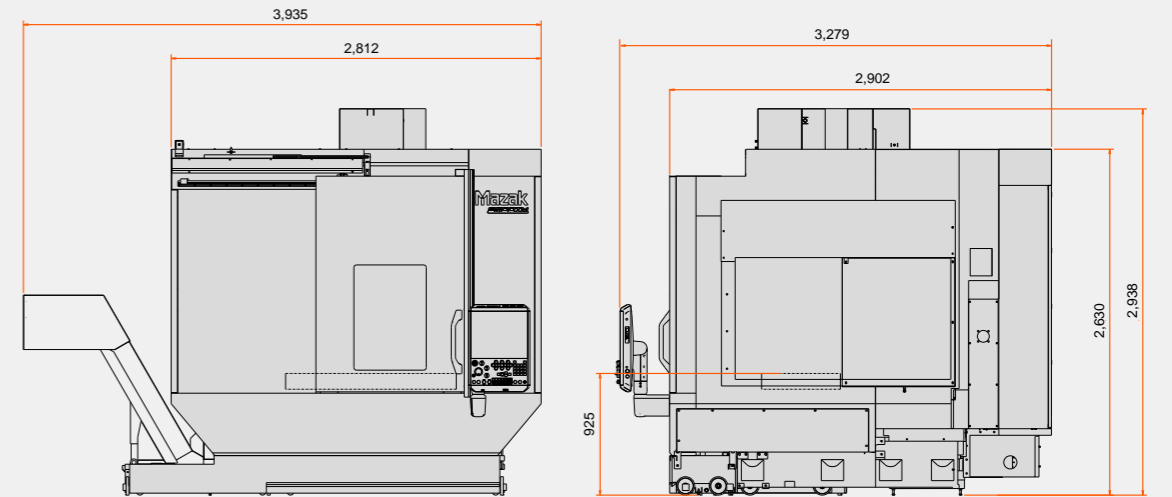

VCN-700

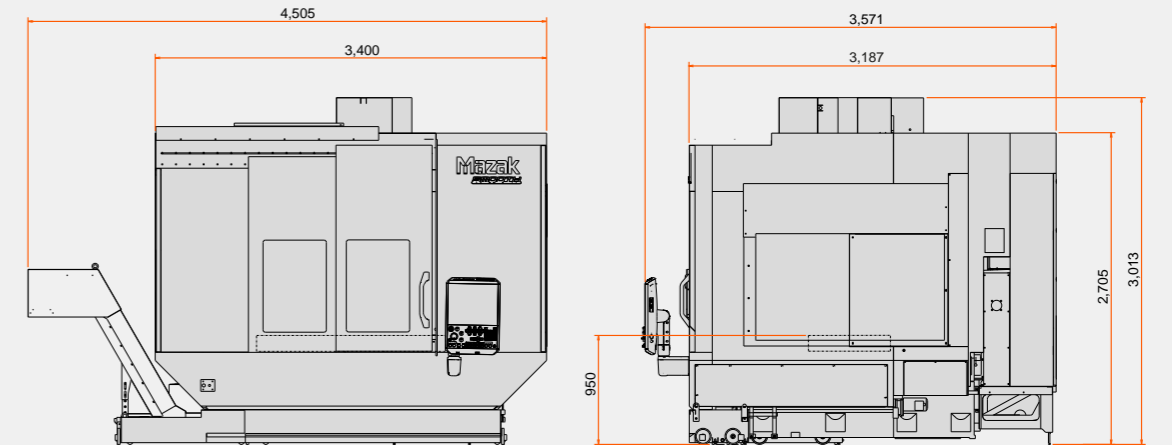

All models shown with optional hinge type conveyor. Machine overall width dimensions may vary depending on conveyor supplier.

Mazak

Yamazaki Mazak U.K. Ltd.

Badgeworth Drive, Worcester WR4 9NF
TEL: +44(0)1905 755 755

www.mazakeu.com

- Specifications are subject to change without notice.
- This product is subject to all applicable export control laws and regulations.
- The accuracy data and other data presented in this catalogue were obtained under specific conditions. They may not be duplicated under different conditions (room temperature, workpiece materials, tool material, cutting conditions, etc.).
- Unauthorized copying of this catalogue is prohibited.